

# ROXUL SAFE™ Applications Guide

Fire blocks, firestops, and rated assemblies



3

Introduction

4

ROCKWOOL Solutions  
for Fire Separation and  
Firestopping

6

Benefits in Fire Resistant  
Assemblies

8

Products

Project  
**The Ritz-Carlton Hotel and  
Condominium in Toronto, Canada**

Materials  
ROXUL SAFE™

Architect  
Page + Steele Architects

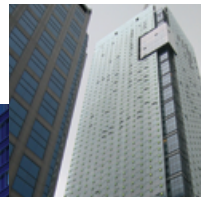

## Introduction

Building fire resistance is a critical consideration for designers and builders. A complex system of fire blocks, firestops, and rated assemblies is needed to resist the propagation of flame and smoke and to keep building occupants safe in the case of a fire. The ROXUL SAFE™ Applications Guide covers the use of these stone wool products in maintaining fire resistance and the continuity of fire separations as required by the National Building Code of Canada, 2015 Edition (the “Building Code”). ROXUL SAFE™ stone wool products have been tested and shown to be non-combustible and is in compliance with a number of standards referenced by the Building Code. This Guide is intended to give general guidance on suitable fire-first applications for ROCKWOOL stone wool insulation. Additionally, a short primer on stone wool properties and code considerations is provided.

ROCKWOOL stone wool products addressed in this guide include:

- ROXUL SAFE™
- ROXUL SAFE™ 45
- ROXUL SAFE™ 55 & 65



# ROCKWOOL Solutions for Fire Separation and Firestopping

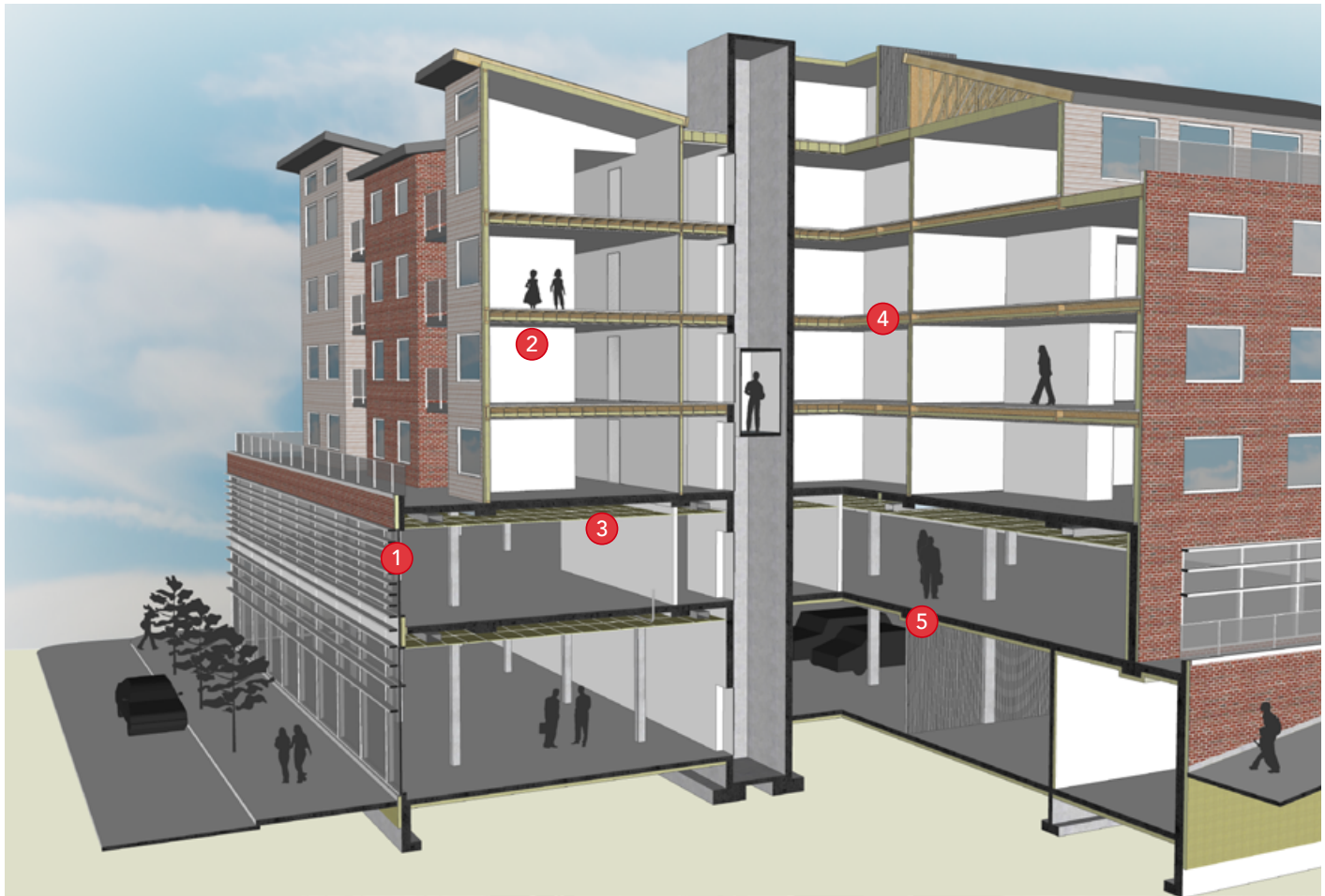

- 1 Curtain Wall Firestopping
- 2 Rated Interior Floor Assembly
- 3 Firestopping at Floor and Wall Penetrations
- 4 Party Wall Fire Blocking
- 5 Fire Rated Metal Panel

ROCKWOOL has developed a wide variety of fire-resistant stone wool insulation products for residential, commercial and industrial applications. A number of these stone wool products, including

ROXUL SAFE™, ROXUL SAFE™ 45 and ROXUL SAFE™ 55 & 65 have unique properties which make them especially suitable for fire safety applications.

# It's more than safe. It's ROXUL SAFE™

ROCKWOOL has made fire-safing projects easier by providing a comprehensive lineup of the highest-performing insulation solutions.

In addition to providing superior fire and sound protection, ROXUL SAFE™ products also contribute to enhancing the efficiency of a building envelope as ROCKWOOL products are dimensionally stable and will not expand or contract due to temperature variances. These attributes result in optimal energy-saving thermal performance which is maintained over the lifetime of a building envelope.

## ROXUL SAFE™

Exterior curtain wall, head of wall, floor-to-wall

ROXUL SAFE™ is a non-combustible, lightweight and water-repellent semi-rigid insulation board that provides fire-stopping and acoustical insulation properties. Specifically engineered and produced as a fire-stopping material for commercial, industrial and residential buildings, it can also be used for interior top-of-wall, through-wall penetrations and floor assemblies where fire stopping is required or desired.

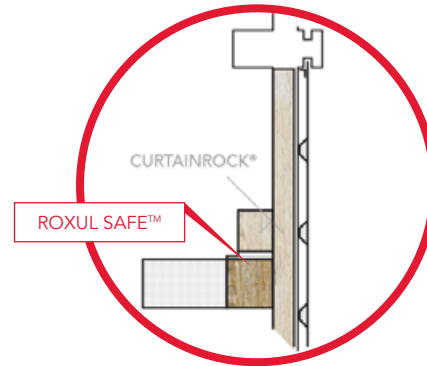

## ROXUL SAFE™ 45

Party wall - residential

ROXUL SAFE™ 45 is a semi-rigid stone wool insulation board product used as a fire-stopping and fireblocking material in concealed spaces in multi-unit residential buildings. Measured to fit, ROXUL SAFE™ 45 is easily installed, non-combustible and offers excellent acoustical and thermal properties. It also does not promote growth of fungi or mildew and is water repellent.

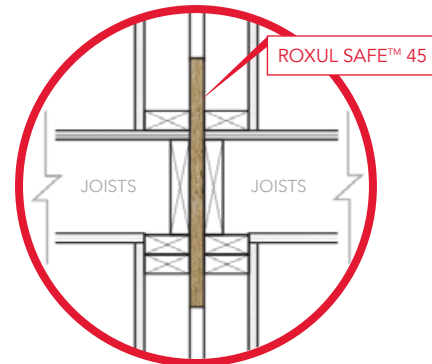

## ROXUL SAFE™ 55 & 65

Exterior metal building

These products are designed for exterior and interior non-load-bearing, steel-faced firewall applications where a fire resistance of at least one hour is required. ROXUL SAFE™ 65 holds a fire resistance rating of one hour, while ROXUL SAFE™ 55 holds a fire resistance rating of two hours – both from the interior side. Both products allow builders to reduce the required separation and increase the area of buildings in close proximity to each other.

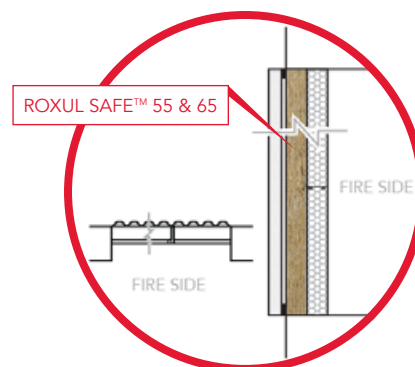

# Benefits in Fire Resistant Assemblies

ROXUL SAFE™ stone wool products are an excellent choice for fire-first applications based on the following tested properties:

### Non-combustible

Stone wool does not contribute to the spread of smoke and fire, and is naturally fire resistant, so does not rely on chemical flame retardants for fire resistance. It will also not release toxic gases or smoke when exposed to high heat.

### Dimensional Stability

Stone wool insulation is resistant to in-service temperature fluctuations, maintaining its shape and properties over time across a wide range of

temperatures. When installed in framing cavities, it will maintain a snug fit providing reliable fire resistance of wall and floor assemblies in the case of fire.

### Ease of Use

Stone wool products are lightweight making them easy to transport and install. The insulation boards/batts can be cut to create various shapes as needed for fire blocking and other fire applications.

Properties	Test Standard	Result
Combustibility	CAN/ULC S114	Non-combustible
Flame Spread Rating	CAN/ULC S102	0
Smoke Developed Classification	CAN/ULC S102	0
Ignition Temperature	-	None
Melting Temperature	-	1177°C
Behavior during Fire Explosion	-	Stays in place

### Code Considerations

Fire resistant properties of stone wool in general are recognised by the Building Code, and stone wool is explicitly permitted for a number of applications such as:

- Additional fire resistance rating when used as insulation in walls per Table D-2.3.4.D in Appendix D. Products used in this application should conform to CAN/ULC-S702, “Mineral Fibre Thermal Insulation for Buildings” and have a minimum density of 1.22 kg/m<sup>2</sup>.
- Omission of fire blocks within a wall assembly per Article 3.1.11.2.
- Fire blocks in combustible buildings per Sentences 3.1.11.7.(7) and 9.10.16.3.(3)
- Protection of combustible insulation and foam plastic insulation per Articles 3.1.5.14 and 3.1.5.14.

Tested applications of stone wool are also permitted to be used to satisfy the requirements of the Building Code.

### Stone Wool Fire Resistance

Fire resistance refers to the ability of a material to withstand exposure to fire and continue to perform its intended function. Building materials are often assigned a fire resistance rating on the basis of testing to specified standards. Fire resistance rating is defined by the Building Code as the time in minutes or hours that a material or an assembly of materials will withstand the passage of flame and transmission of heat when exposed to fire under specified conditions. Typically, building elements and assemblies are designed as continuous fire separations with specified fire rating (time to failure) in order to act as a barrier against fire spread beyond the compartment of origin.

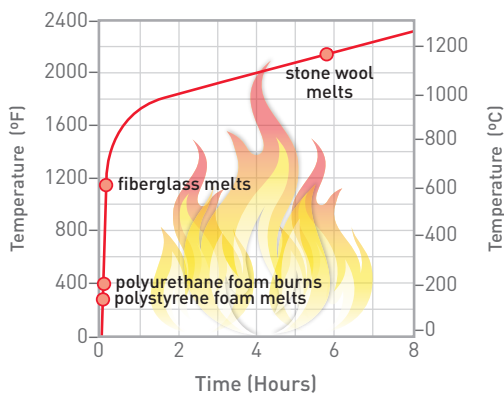

### Temperature Development in a Standard Fire (ASTM E119)

ROCKWOOL stone wool is a non-combustible insulation material consisting of rock fibres made from basalt rock and slag. As a result of its non-combustible nature and density, ROCKWOOL stone wool provides exceptional thermal properties and is able to withstand temperatures of up to 1177°C (2150°F) without burning or melting. This makes it an excellent barrier for preventing fire spread and allows it to provide or contribute to the fire resistance of building elements and assemblies. ROXUL SAFE™ stone wool has been tested and may be used as a component in wall or floor assemblies, as protection for combustible insulation, or as part of firestop systems.

# Curtain Wall Firestopping

## Assembly Shown

- Mullion mounting brackets
- Transom
- Spandrel panels/Vision panels
- ROCKWOOL CURTAINROCK®
- ROXUL SAFE™
- Installed between the floor and curtain wall assembly along with smoke sealant.

## Alternate Assemblies

Several design configurations which have been tested to USA standards are available\*. Some example cUL listings include:

- System No. CW-D-2014
- System No. CW-D-2018
- System No. CW-S-1021

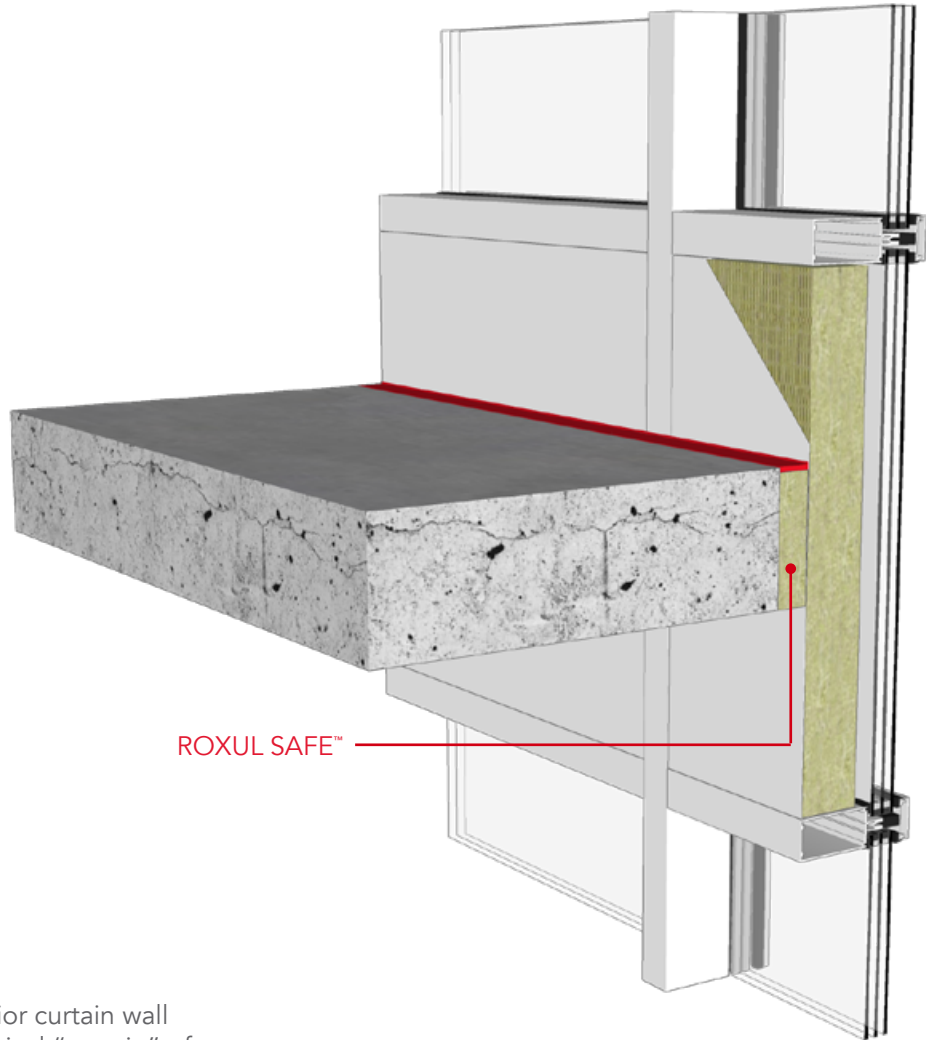

Energy Savings  
Moisture Resistance  
High Vapor Permeability

## Description

This application involves a glazed exterior curtain wall system which includes a continuous vertical “curtain” of glass, often in combination with metal panels, supported by vertical and horizontal mullions. The curtain wall system is suspended away from the floor slab in order to achieve continuity of the glass curtain across building floors, which results in a gap between the slab edge and curtain wall assembly. Maintaining the continuity of floor slab fire separation across this space requires a specially designed firestop system. A majority of such tested firestop systems

\* These listings are based on USA testing (UL listings) - acceptability in Canadian jurisdictions is determined by the Authority Having Jurisdiction include stone wool insulation.

ROCKWOOL stone wool insulation may be used where insulation is required as illustrated in the diagram. The density and thickness of the insulation is typically specified by a listing.

ROCKWOOL CURTAINROCK® is designed specifically for use as curtain wall insulation and ROXUL SAFE™ may be used as the forming material component of the firestop system between the floor and exterior curtain wall assembly.



### Code Discussion

The curtain wall firestop system addresses the continuity of a floor assembly where it abuts an unrated curtain wall assembly. The Building Code requires the continuity of a floor assembly to be maintained to an exterior wall assembly in order to prevent floor-to-floor fire spread via the gap created between the exterior wall and floor assemblies; however, firestopping at the junction between a non-rated exterior

curtain wall system and a rated floor is a unique condition, which is not explicitly addressed by the Building Code. There are currently no approved Canadian tests for this condition and it is often addressed as an engineering judgement based on the USA standard, ASTM E2307 "Standard Test Method for Determining Fire Resistance of Perimeter Fire Barrier Systems Using Intermediate-Scale, Multi-Story Test Apparatus".

### Testing Information

#### ASTM E2307

*Standard Test Method for Determining Fire Resistance of Perimeter Fire Barriers Using Intermediate-Scale, Multi-Story Test Apparatus*

Engineering judgement may be required for use of products tested to the USA standard in Canada.

### SUMMARY

**ROXUL SAFE™** insulation is commonly installed as a part of a curtain wall firestopping system. Stone wool insulation is employed to fill the void space between a rated floor and exterior wall (curtain wall system) in order to prevent the passage of flame between floors. Several assemblies incorporating stone wool firestops have been tested to AS™ E2307 and are commonly used in Canadian jurisdictions.



Stone wool insulation being installed as part of a curtain wall firestopping system

# Rated Interior Floor Assembly

## Assembly Shown

- Floor finish
- Subflooring (plywood, lumber, etc.)
- Framing (wood-, steel-, or I-joists)
- ROXUL SAFE™
- (ROCKWOOL SAFE'n'SOUND®)
- Resilient channels
- Fire rated membrane (gypsum)

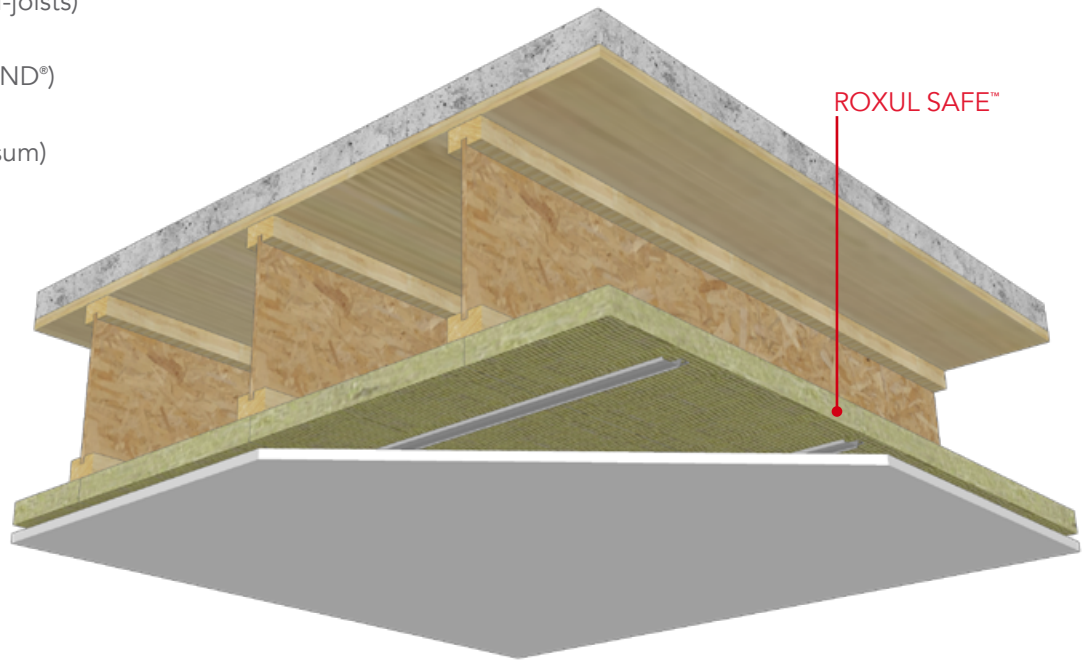

Energy Savings  
Moisture Resistance  
High Vapor Permeability

## Description

A rated wood- or steel-framed floor assembly includes a rated membrane, such as one or more layers of fire rated gypsum board, supported by framing members. Wood- or steel-framed floor assemblies typically include stone wool insulation to improve sound transmission which may have the added benefit of improving the fire resistance rating of some assemblies. The benefits of stone wool insulation in improving fire resistance ratings are documented in the National Research Council (NRC) report Fire Resistance of Floor Assemblies in Multi-Family Dwellings<sup>1</sup>, which states that rock fibre (i.e. stone wool) insulation is able to remain in place longer than glass fibre and increases the fire resistance of floor assemblies with wood I-joists and solid wood joists with one layer of gypsum board compared to an assembly with no insulation. The test documented in the NRC report showed that the insulation provided protection for the wood framing for a period of time following the failure of the membrane (gypsum), thus delaying the time to failure of the assembly.

<sup>1</sup> Sultan, M.A. Fire Resistance of Floor Assemblies in Multi-Family Dwellings. Construction Technology Update No. 20, Institute for Research in Construction, National Research Council Canada, Sept. 1998.

## Alternate Assemblies

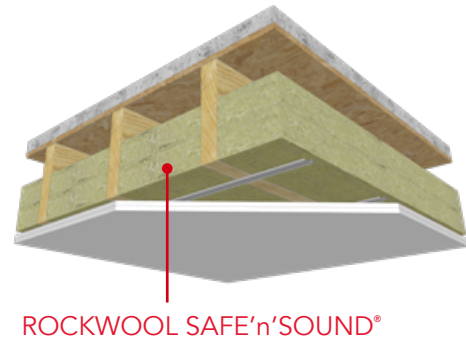

ROXUL SAFE™ or SAFE'n'SOUND® are most suitable for this application and may be used where insulation is required as illustrated in the diagram above.

### Code Discussion

Subsection 3.2.2. of the Building Code prescribes fire resistance rating for floor assemblies based on building height, area, and use.

Floor assemblies which require a fire resistance rating are required by the Building Code to be assigned a fire resistance rating based on:

- Appendix D of the Building Code,
- testing in conformance with CAN/ULC S101, "Fire Endurance Tests of Building Construction and Materials".

Appendix D of the Building Code may only be used to determine the rating of assemblies with a maximum fire resistance rating of 90min. Where assemblies with fire resistance rating greater than 90min are necessary, tested assemblies are required. Furthermore, Appendix D of the Building Code does not provide additional fire resistance rating for stone wool in floor assemblies. However, as noted previously, the use of stone wool insulation is able to increase the fire resistance rating of certain assemblies. Careful review is required to determine if the inclusion of stone wool insulation will alter the fire resistance rating of a particular assembly.

### Testing Information

CAN/ULC S101

*Fire Endurance Tests of Building Construction and Materials*

Engineering judgement may be required for use of products tested to the USA standard in Canada.

### SUMMARY

ROXUL SAFE™ insulation is commonly installed as a part of a curtain wall firestopping system. Stone wool insulation is employed to fill the void space between a rated floor and exterior wall (curtain wall system) in order to prevent the passage of flame between floors. Several assemblies incorporating stone wool firestops have been tested to AS™ E2307 and are commonly used in Canadian jurisdictions.



Stone wool insulation being installed as part of a curtain wall firestopping system

# Firestopping at Penetrations

## Assembly Shown

- Fire rated wall or floor assembly
- Penetrations (metal or plastic)
- Listed fire stop within annular space
- Consists of ROXUL SAFE™ and smoke sealant
- Pipe insulation to provide T-rating

## Alternate Assemblies

Several design configurations were available. Some example cUL Listings include:

- cUL System No. C-AJ-1519
- cUL Design No. W-J-1169

Energy Savings  
Moisture Resistance  
High Vapor Permeability

## Description

In order to allow building services to be routed throughout a building, there is often the need for penetrations through rated assemblies. Such penetrations are required to be protected to avoid compromising the fire resistance rating and fire separation property of the fire rated assembly. Listings for rated assemblies should be reviewed for limits on the number of penetrations permitted. The Building Code also places restrictions on the types and locations of penetrations.

\* T-rating indicates the length of time before the the temperature on the non-fire side of a penetration exceeds 163°C (325°F) above ambient temperature.

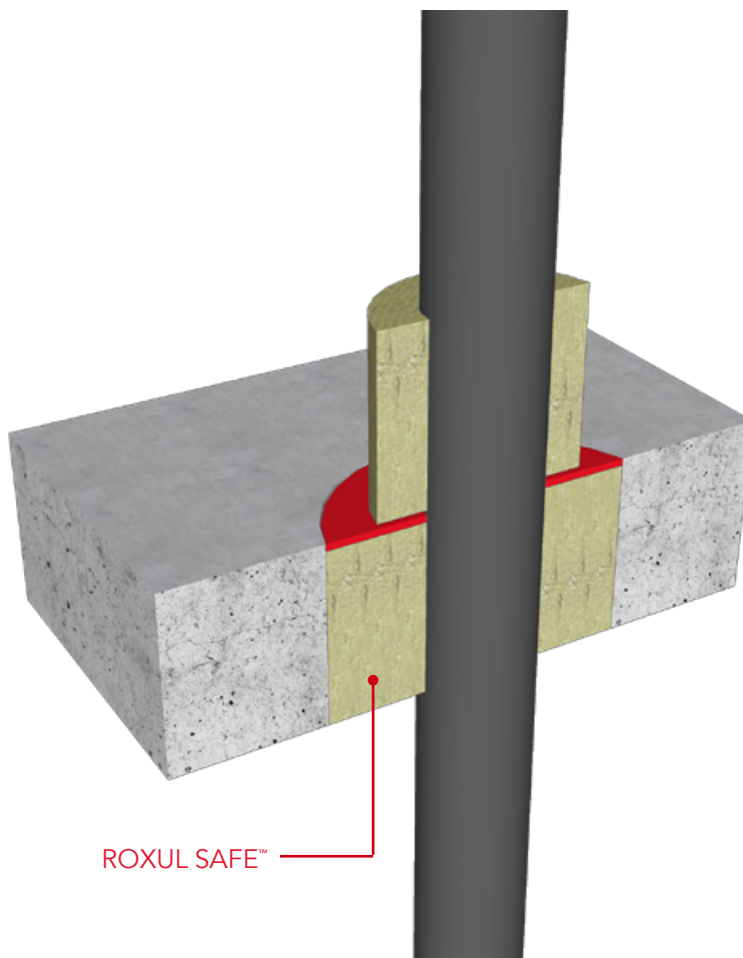

ROXUL SAFE™

ROXUL SAFE™ may be used as the forming material component of the firestop system with the annular space. The density and thickness of the insulation is typically specified by a listing.

### Code Discussion

Subsection 3.1.9 of the Building Code discusses penetrations in fire separations and fire rated assemblies. Fire stops are required for all penetrations of a fire separation or a membrane which forms part of a fire separation. This is required in order to maintain the integrity of the fire separation or assembly and to prevent fire spread throughout the building. The penetrations are required to be sealed with a fire stop system tested to CAN/ULC-S115, "Fire Tests of Firestop Systems" or cast directly into concrete.

An F-rated fire stop system is designed to remain in the opening and prevent the passage of flame through the opening or the occurrence of flaming on the unexposed side during the fire test for the duration of the rating period.

An FT-rated firestop system is designed to meet the F-rating requirement, as well as limit heat transmission through the firestop system during the rating period such that the temperature on the unexposed side of the firestop system is not more than 163°C (325°F) above its initial temperature.

### Testing Information CAN/ULC S115

*Fire Tests of Firestop Systems*



Stone wool insulation installed in annular space of rated floor assembly

Tested fire stop systems are required to have an FT-rating where the penetration is through:

- a firewall,
- a horizontal fire separation between the building above and a basement parking garage, when constructed as a separate building in accordance with Article 3.2.1.2 of the Building Code, or
- a rated fire separation between a horizontal service space and occupied spaces below.

Penetrations through other assemblies are permitted to have an F-rating. Stone wool insulation is a major component of firestop systems and is used both within the annular space to achieve the F-rating, and as pipe insulation to augment or achieve the T-rating.

### SUMMARY

Penetrations are often needed in rated fire assemblies in order for services to be routed throughout the building. A firestopping system is required in order to maintain the integrity of a rated wall or floor assembly. **ROXUL SAFE™** stone wool installed in the annular space in conjunction with appropriate smoke sealant provides a Building Code permitted solution. Stone wool can also be used as pipe insulation to achieve the required T-rating.

# Party Wall Fire Blocking

## Assembly Shown

- Rated interior wall assemblies (wood or steel stud)
- ROXUL SAFE™ 45
- Blocks vertical space in double stud wall assembly formed at the intersection of the floor assembly and walls.

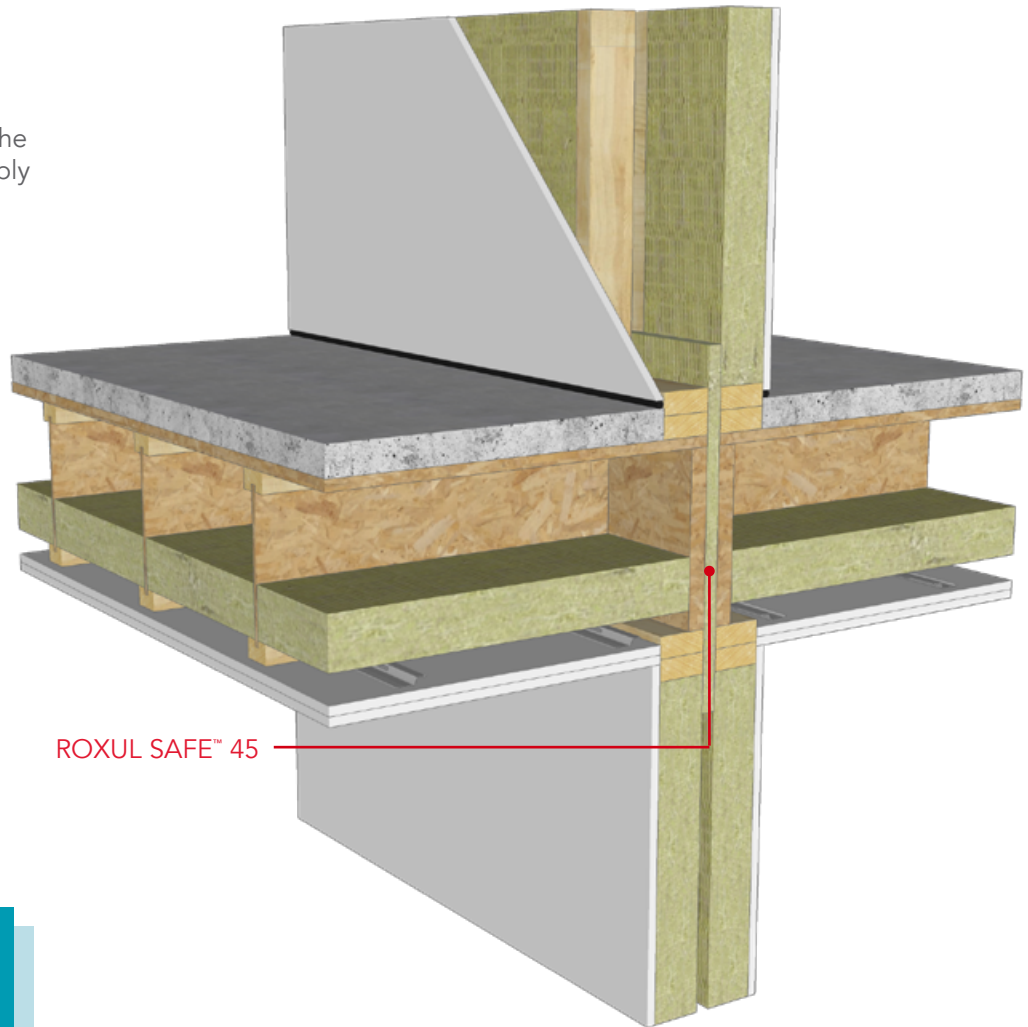

Energy Savings  
Moisture Resistance  
High Vapor Permeability

## Description

Party walls are often included in the design of a building for a number of reasons including sound attenuation. This wall design may include a vertical space between the studs which can sometimes span several storeys, and can potentially lead to rapid fire spread throughout a building. Sentence 3.1.11.7.(7) of the Building Code requires that appropriate fire blocking be provided within this space in order to prevent fire spreading within this vertical space.

ROXUL SAFE™ 45 is a suitable fire blocking material for separating concealed spaces in combustible buildings to control the risk of flame spread between floors.

### Code Discussion

Fire blocking is required within concealed spaces in a wall assembly at every floor level as described in Article 3.1.11.2 of the Building Code.

The Code permits the use of semi-rigid stone wool insulation as fire blocking in the vertical space at the intersection between a floor assembly and the double stud wall where the following conditions are met:

- The building is permitted to be of combustible construction
- The width of the vertical space is not more than 25mm

### Testing Information

CAN/ULC S115

*Fire Tests of Firestop Systems*

### The insulation:

- has a density not less than 45kg/m<sup>3</sup>
- is securely fastened to one set of studs
- extends below the bottom plate and above the top plate of the floor assembly
- completely fills the space between the headers and wall plates

## SUMMARY

ROXUL SAFE™ 45 is commonly installed as a fire block in party wall assemblies. Article 3.1.11.2 of the Building Code requires that fire blocks separate concealed spaces to control the risk of flame spread. Stone wool fire blocking prevents the passage of flame between floors in combustible buildings providing occupants with valuable time to evacuate the building.

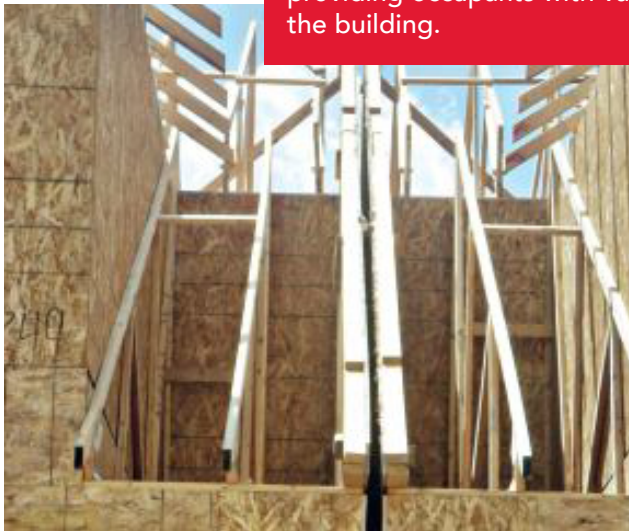

Party wall framing requires fire separation between units and fire blocking to prevent the vertical propagation of fire

# Fire Rated Metal Panel

## Assembly Shown

- Steel panel at interior face
- ROXUL SAFE™ 55 - 2 hr fire resistance rating
- ROXUL SAFE™ 65 - 1 hr fire resistance rating
- Steel panel at exterior face

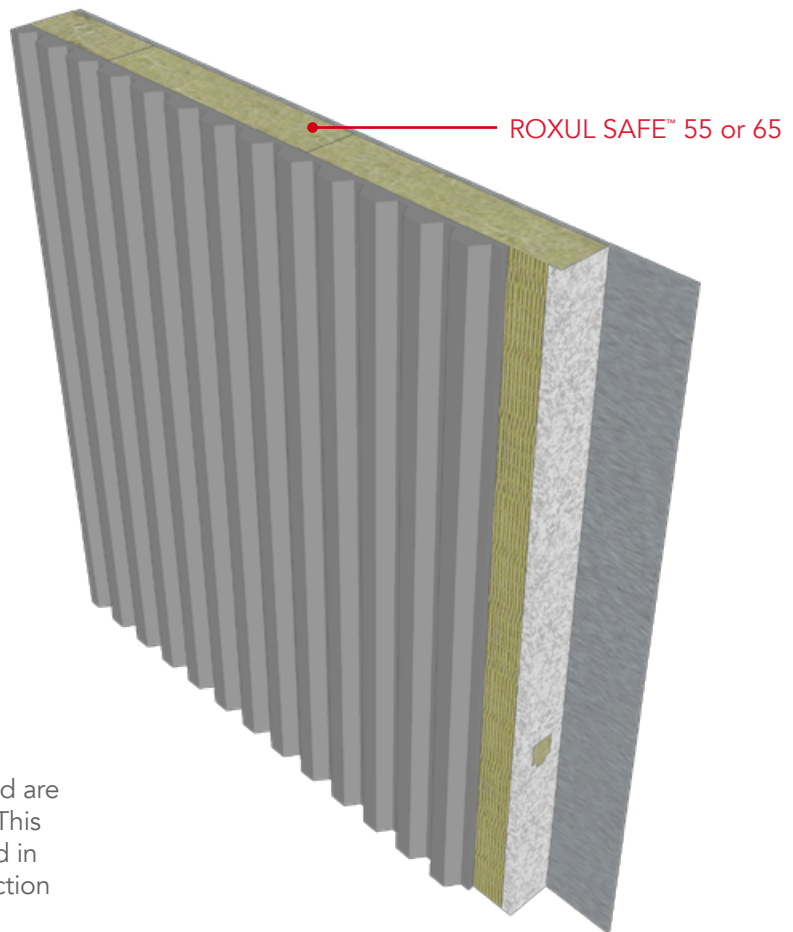

Energy Savings  
Moisture Resistance  
High Vapor Permeability

## Description

Fire rated panels can be made from stone wool, and are typically protected on both sides by metal panels. This assembly is typically used in industrial buildings and in buildings where cost savings and speed of construction are desired.

A 1-hour or 2-hour fire resistance rating from the interior side allows builders to reduce the required separation between buildings.





### Code Discussion

This assembly is typically a propriety listing which prescribes generic stone wool as one of the components. The panels are tested in accordance with CAN/ULC S101, and the rating is derived mainly from the stone wool core. This assembly is designed for use both as exterior and interior walls and is able to provide fire resistance ratings of up to 3h or more. :

- The building is permitted to be of combustible construction
- The width of the vertical space is not more than 25mm

### The insulation:

- has a density not less than 45kg/m<sup>3</sup>
- is securely fastened to one set of studs
- extends below the bottom plate and above the top plate of the floor assembly
- completely fills the space between the headers and wall plates

### Testing Information

CAN/ULC S101

*Fire Endurance Tests of Building Construction and Materials*

### SUMMARY

Metal panel assemblies require stone wool insulation to achieve the required fire resistance rating. ROXUL SAFE™ 55 or 65 stone wool insulation sandwiched between two layers of metal can provide a fire rating of up to 3h or more, ensuring adequate separation in the case of fire. Rated metal panels are typically proprietary and must be tested to CAN/ULC S101.



Typical metal panel assembly with stone wool insulation installed between metal layers

At the ROCKWOOL Group, we are committed to enriching the lives of everyone who comes into contact with our solutions. Our expertise is perfectly suited to tackle many of today's biggest sustainability and development challenges, from energy consumption and noise pollution to fire resilience, water scarcity and flooding. Our range of products reflects the diversity of the world's needs, while supporting our stakeholders in reducing their own carbon footprint.

Stone wool is a versatile material and forms the basis of all our businesses. With approx. 10,500 passionate colleagues in 38 countries, we are the world leader in stone wool solutions, from building insulation to acoustic ceilings, external cladding systems to horticultural solutions, engineered fibres for industrial use to insulation for the process industry and marine & offshore.

AFB®, CAVITYROCK®, COMFORTBATT®, CONROCK®, CURTAINROCK®, ROCKBOARD®, TOPROCK®, MONOBOARD®, ROXUL® are registered trademarks of the ROCKWOOL Group in USA and ROXUL Inc. in Canada.

ROCKWOOL™, COMFORTBOARD™, FABROCK™, ROXUL SAFE™, ROCKWOOL PLUS™, and AFB evo™ are trademarks of the ROCKWOOL Group in USA and ROXUL Inc. in Canada.

SAFE'n'SOUND® is a registered trademark used under license by Masonite Inc.